

GENSET MODEL	ENGINE MODEL	ALTERNATOR MODEL	WEIGHT			CENTRE OF GRAVITY FROM FRONT FACE [in]
			WITH LUBE OIL	WITH OIL & WATER	WITH OIL, WATER & FUEL	
K7.5-1	0905-B02	LU1148	417	424	468	TBC
K9.5-1	01105-B02	LU1148	417	424	468	TBC
P9.5-4	4030-11G	LU1148	438	445	489	807
P12.5-1	V1905-B02	LU1140	508	513	557	873
P15-8	4040-22G	LU1144	572	580	627	877
P22-6	4040-22G	LU1144	589	596	640	895

METRIC 370-7256

SOCKET	DESCRIPTION	SIZE
A	FUEL LUBE SWITCH	1" BSP
B	FUEL GAUGE	1/2" BSP
C	FUEL GAUGE	1/2" BSP
D	FUEL SUPPLY	1/2" BSP
E	FUEL RETURN	1/2" BSP
F	RELOIL SUPPLY	1" BSP
G	FUEL DRAIN	1" BSP
H	COOLANT DRAIN	1/2" BSP
J	LUBE OIL DRAIN	1/2" BSP
K	RELOIL RETURN	1" BSP

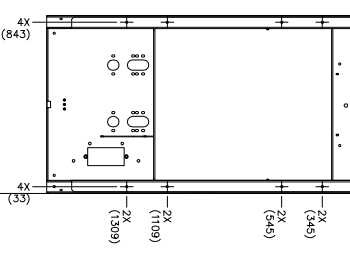
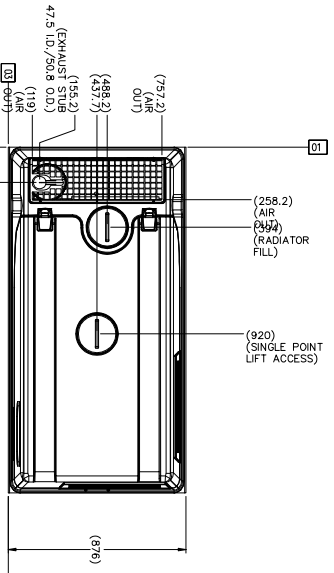
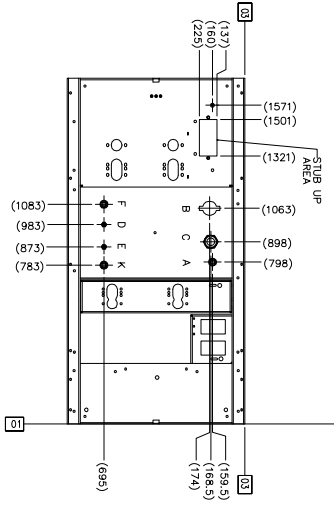
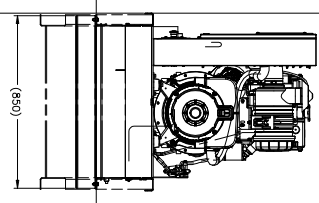
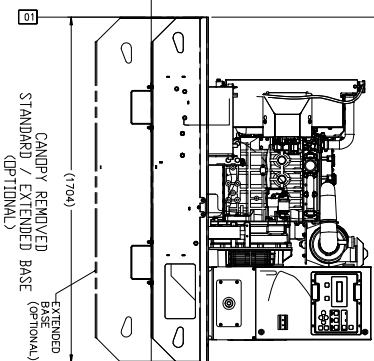
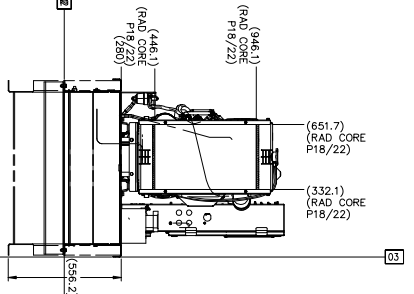
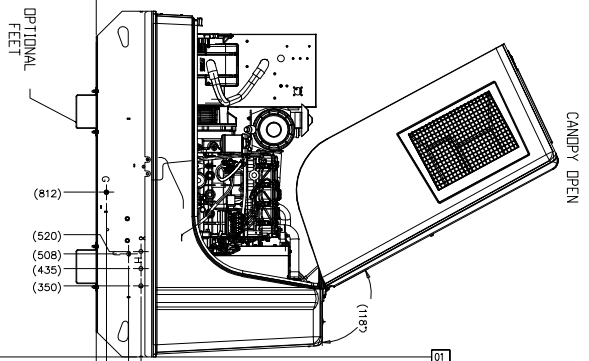

GROUND FIXING LOCATIONS -
TANKBASE
VIEW FROM BOTTOM

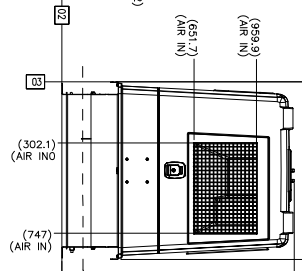
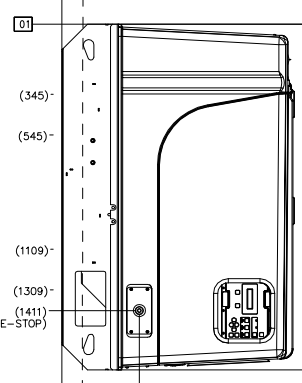
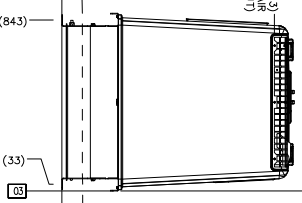
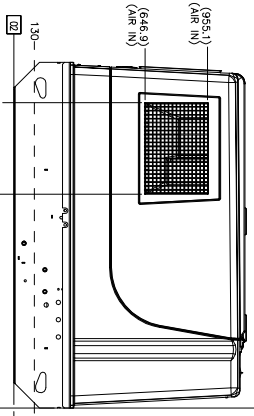

REDUCED HEIGHT
SPEC. CASE (OPT)

GROUND FIXING LOCATIONS -
TANKBASE
VIEW FROM BOTTOM

SOCKET	DESCRIPTION	SIZE
A	FUEL LUBE SWITCH	1" BSP
B	FUEL GAUGE	1/2" BSP
C	FUEL GAUGE	1/2" BSP
D	FUEL SUPPLY	1/2" BSP
E	FUEL RETURN	1/2" BSP
F	RELOIL SUPPLY	1" BSP
G	FUEL DRAIN	1" BSP
H	COOLANT DRAIN	1/2" BSP
J	LUBE OIL DRAIN	1/2" BSP
K	RELOIL RETURN	1" BSP

PERKINS

370-7256 RFD 05 1E

GENERAL AR-COMPL