

ITEM QTY.	AUXILIARY CONNECTORS	DIM. X	DIM. Y	DIM. Z
A 1	FUEL INLET 3/4" BSP	1607	150	523
B 1	FUEL RETURN 3/4" BSP	1707	150	523
C 1	OIL DRAIN OUTLET 3/4" BSP	1990	50	523

WEIGHT (kg)	
(WITH OIL)	7474
(WITH OIL & WATER)	7822

ITEM QTY.	EXCLUSIVELY SERVICEABLE PART DESCRIPTION	DRAWING NO.
Z 1	FUEL COOLER GROUP	MGS6013

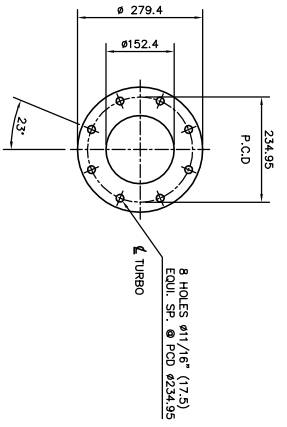

EXHAUST OUTLET DETAILS
SCALE 2.5:1

ITEM QTY.	DESCRIPTION	DRG./P/PART NO.
1	ENGINE/ALTERNATOR COMBINATION	366-4300
1	SKIDBASE GROUP	MGS4313
1	FUEL LINE GROUP	MGS4327
1	CONTROL PANEL (IF FITTED)	-
1	BATTERY GROUP	367-4948
1	RADIATOR PEDESTAL GROUP	MGS4264
1	WATER CIRCUIT ASSY GROUP	MGS4283
1	CHARGE AIR ASSY GROUP	MGS4266
1	BREAKER (IF FITTED)	-
1	COUPLING GROUP	MGS4212
1	PANEL UPLIFT GROUP	433-1360
1	SENDERS GROUP	MGS4312
1	HAZARD LABELS GROUP	MGS4211
1	BMW BRAND LABELS GROUP	MGS4425
1	PULLEY GUARD GROUP	MGS4397

* ITEMS NOT SHOWN

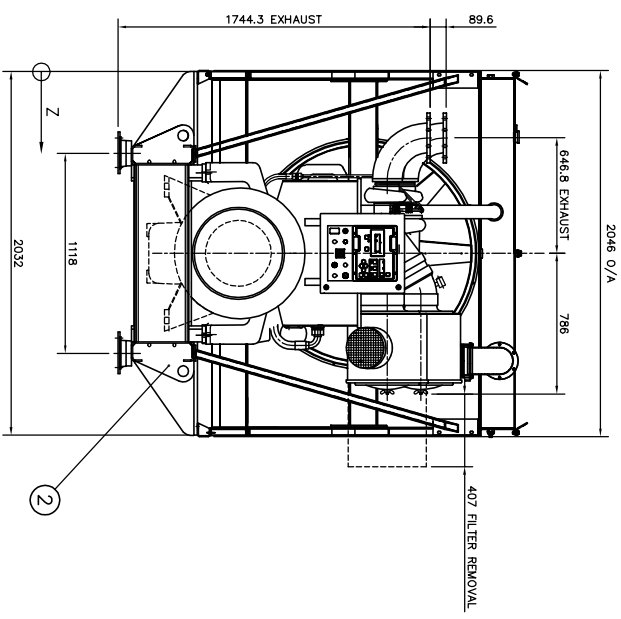
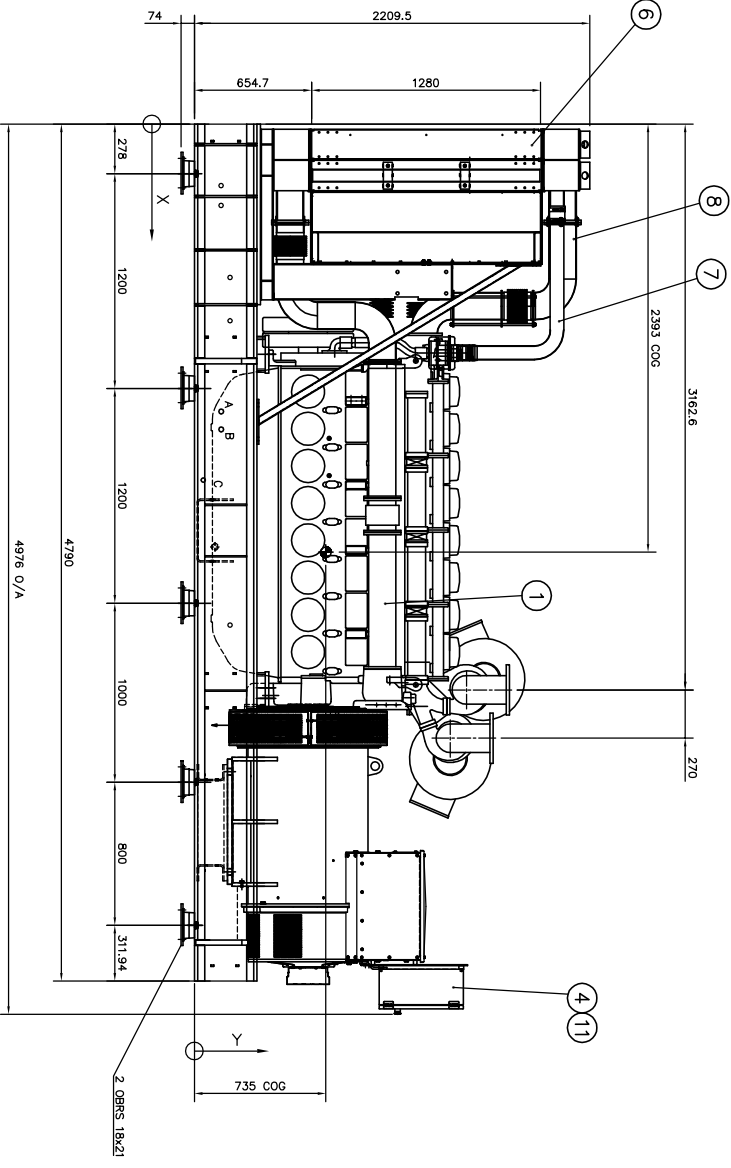

REV.	DESCRIPTION	BY	DATE	CHKD.	DATE
1	CONRAD RADIATOR INTRODUCED	28477	G.O.	08/19/03	
2	ENGINE NOW LISTED AS 400BTAC/A WAS 400BTAC	20784	G.O.	18/04/02	
3	MARPO REVISED; ALTERNATOR PREVIOUSLY L18724P, WASS & COG REVISED	20482	ICR	03/09/03	
4	REMOVED GENSET ALTERNATOR FROM WEIGHT DATA	ECR20209	C/R	22/09/03	
5	ITEM 2 UPGRADED WITH NEW PT NO. FOR RELEASE OF L8100 ALTERNATOR	ECR20205	C/R	22/09/03	
6	FIRST ISSUE	-	P/K	27/11/00	
7	ISSUE DESCRIPTION	ECR/OCR	BY	DATE	

REV.	DESCRIPTION	BY	DATE	CHKD.	DATE
1	WEIGHT CORRECTED	38172	A.O.	18/12/12	
2	TO SHOW L17124P ALTERNATOR NEW WEIGHTS AND COG	30890	A.O.	12/11/12	
3	TO SHOW NEW BASEFRAME, LAZZA A.L.T. WEIGHTS & COG	30180	A.B.	05/02/10	
4	SERVICEABLE PART 728-629 A1TD TO MGS0013	23480	V.V.	22/09/04	

REV.	DESCRIPTION	BY	DATE	CHKD.	DATE
1	ISSUES EXERT MADE OVERHIMS STATED				
2	ISSUES EXERT MADE OVERHIMS STATED				
3	ISSUES EXERT MADE OVERHIMS STATED				
4	ISSUES EXERT MADE OVERHIMS STATED				
5	ISSUES EXERT MADE OVERHIMS STATED				

REV.	DESCRIPTION	BY	DATE	CHKD.	DATE
1	ISSUES EXERT MADE OVERHIMS STATED				
2	ISSUES EXERT MADE OVERHIMS STATED				
3	ISSUES EXERT MADE OVERHIMS STATED				
4	ISSUES EXERT MADE OVERHIMS STATED				
5	ISSUES EXERT MADE OVERHIMS STATED				

REV.	DESCRIPTION	BY	DATE	CHKD.	DATE
1	ISSUES EXERT MADE OVERHIMS STATED				
2	ISSUES EXERT MADE OVERHIMS STATED				
3	ISSUES EXERT MADE OVERHIMS STATED				
4	ISSUES EXERT MADE OVERHIMS STATED				
5	ISSUES EXERT MADE OVERHIMS STATED				