

0500-4092 A1

REV. No.	DATE	BY	CHKD	APPROVED	DATE
ERK10096	A	1			13/07/2004
ERK10095	B	1			25/11/2004
ERK10010	C	1			18/03/2005

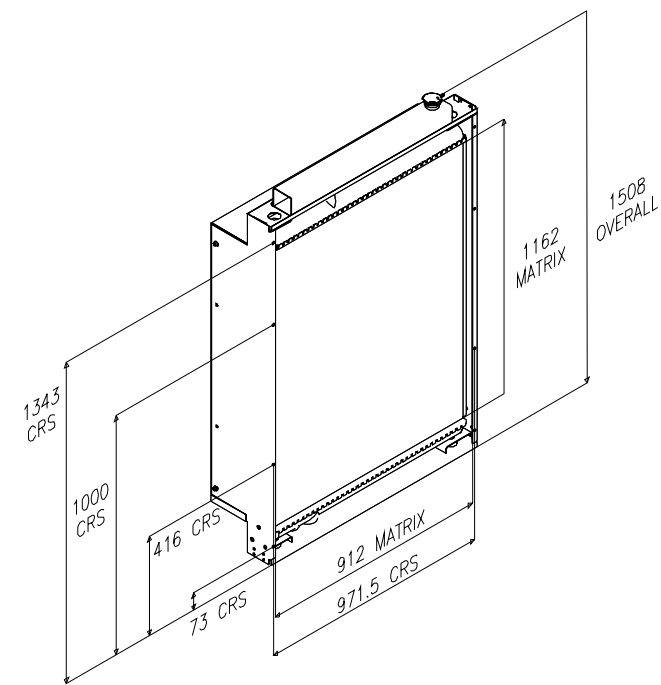

RADIATOR MATRIX 50°C

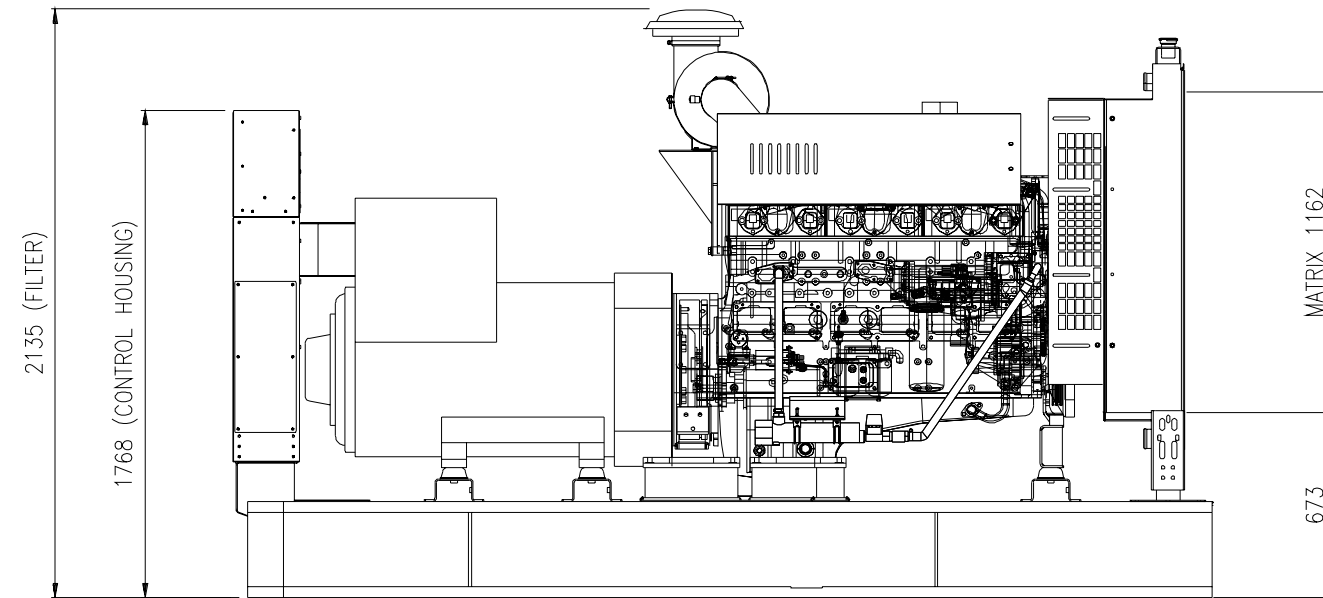

HEAVY DUTY AIR CLEANER - NT ENGINE

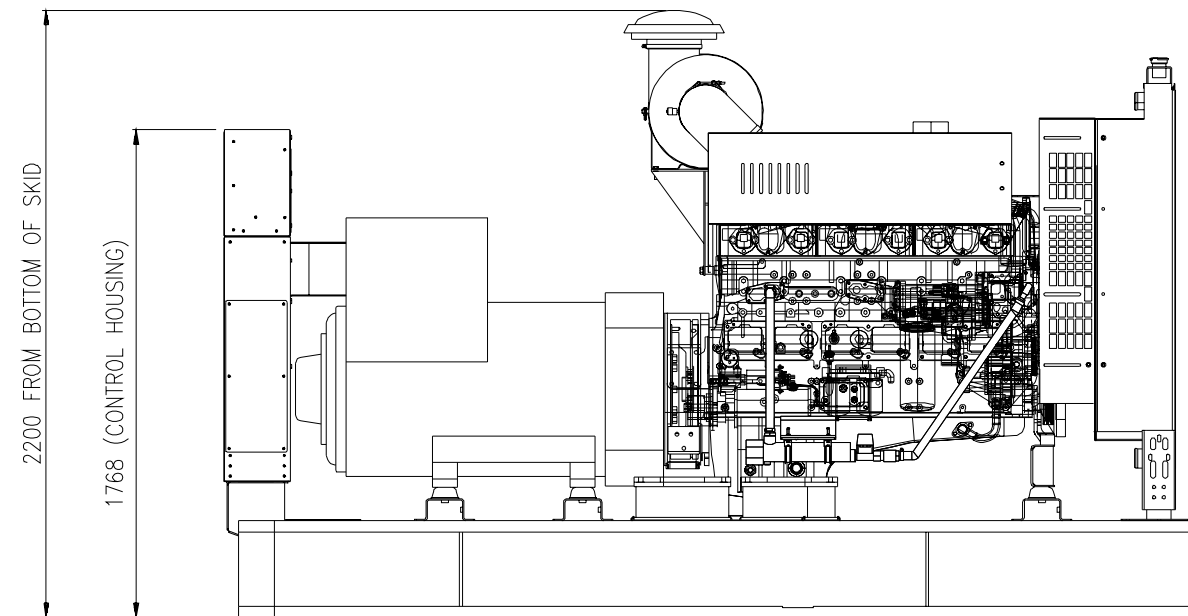

HEAVY DUTY AIR CLEANER - NTA ENGINE

INSTALLATION NOTES:

- BREAKER CONFIGURATION TO SUIT BOTH 400A-630A AND 800A-1600A
- TERMS AND CONDITIONS CAN BE FOUND AT THE FOLLOWING:-  
[www.cumminspower.com/terms](http://www.cumminspower.com/terms)

TOLERANCE UNLESS OTHERWISE SPECIFIED	SYMBOL TO BE USED	NAME	DATE
±0.08	±0.08	JONES	13/07/2004
±0.10	±0.10	ANDREWS	12/10/2004
±0.15	±0.15	BARRETT	12/10/2004

**Cummins Power Generation**  
Columbus Avenue, Manston, Ramsgate  
Kent, CT12 5BF, England, UK

TITLE: GENSSET OUTLINE

SITE CODE: C300

PKG: PGK

0500-4092

SHEET 2 OF 2

ENC. A1

AutoCAD DO NOT SCALE PRINT ANGLE TOL. ±1.0° SCALE: 1:12