

DETAIL A
SCALE: 1:5
(25)

ITEM NO.	QTY	UNIT	DESCRIPTION	NAME
1	1		CONT GP-MANUAL	
2	1		BOX-STORAGE	
3	1		ENGINE AIR	
4	1		RADIATOR GP-ATOR	
5	1		W/G GP-ENGINE	
6	1		COUPLING GP-FLY	
7	1		CRANK GP-TOIL	
8	1		CRANK GP-OIL	
9	1		GENERATOR AIR	
10	1		SENSOR GP-FRESS	
11	1		SENSOR GP-TEMP	
12	1		PANEL GP-COINT -A	
13	1		W/MS GP-ALT	
14	1		FLM GP	
15	1		FLM GP	
16	1		FLM GP	
17	1		BATTERIES	
18	1		W/MS GP	
19	1		W/MS GP	

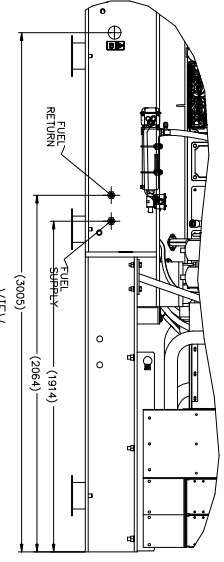

VIEW B-B
SCALE: 1:5
(68)

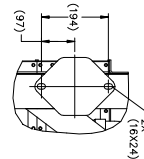
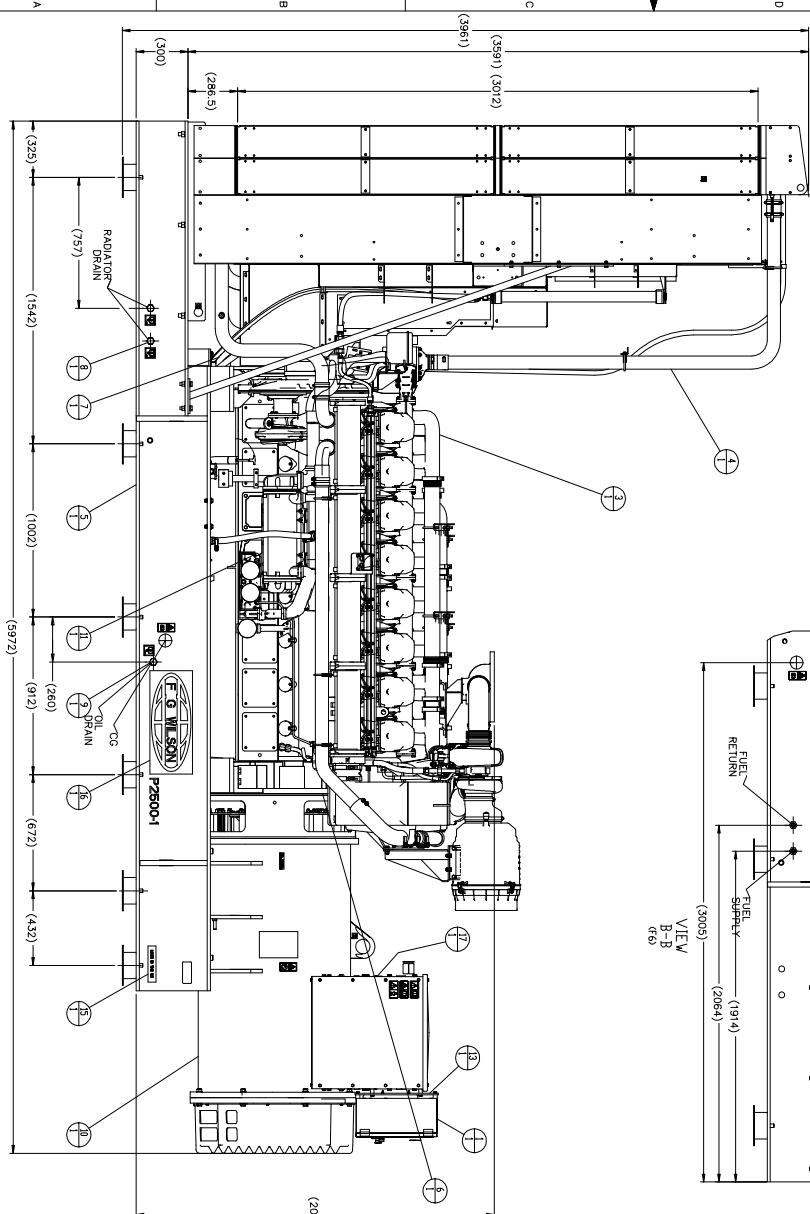

VIEW C-C
SCALE: 1:5
12 PLACES
(97)

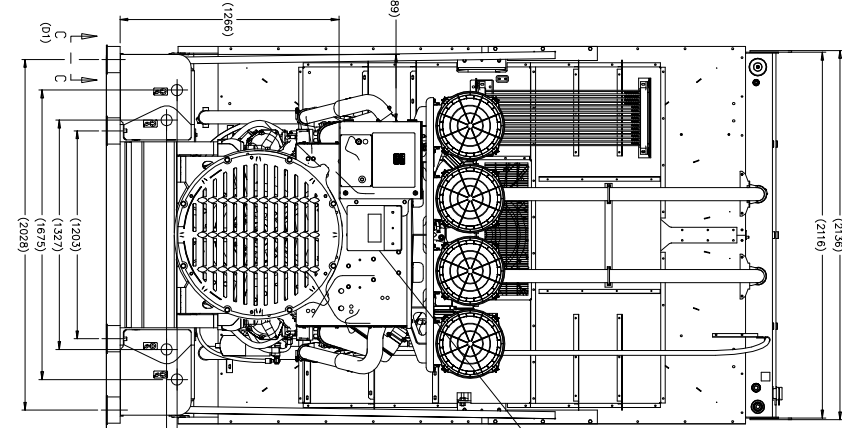

NOTE A: ITEM NOT SHOWN, TO BE SHIPPED
NOTE B: ITEM NOT SHOWN, TO BE SHIPPED
NOTE C: ITEM NOT SHOWN, TO BE SHIPPED
NOTE D: ITEM NOT SHOWN, TO BE SHIPPED
NOTE E: ITEM NOT SHOWN, TO BE SHIPPED
NOTE F: ITEM NOT SHOWN, TO BE SHIPPED
NOTE G: ITEM NOT SHOWN, TO BE SHIPPED
NOTE H: ITEM NOT SHOWN, TO BE SHIPPED
NOTE I: ITEM NOT SHOWN, TO BE SHIPPED
NOTE J: ITEM NOT SHOWN, TO BE SHIPPED
NOTE K: ITEM NOT SHOWN, TO BE SHIPPED
NOTE L: ITEM NOT SHOWN, TO BE SHIPPED
NOTE M: ITEM NOT SHOWN, TO BE SHIPPED
NOTE N: ITEM NOT SHOWN, TO BE SHIPPED
NOTE O: ITEM NOT SHOWN, TO BE SHIPPED
NOTE P: ITEM NOT SHOWN, TO BE SHIPPED
NOTE Q: ITEM NOT SHOWN, TO BE SHIPPED
NOTE R: ITEM NOT SHOWN, TO BE SHIPPED
NOTE S: ITEM NOT SHOWN, TO BE SHIPPED
NOTE T: ITEM NOT SHOWN, TO BE SHIPPED
NOTE U: ITEM NOT SHOWN, TO BE SHIPPED
NOTE V: ITEM NOT SHOWN, TO BE SHIPPED
NOTE W: ITEM NOT SHOWN, TO BE SHIPPED
NOTE X: ITEM NOT SHOWN, TO BE SHIPPED
NOTE Y: ITEM NOT SHOWN, TO BE SHIPPED
NOTE Z: ITEM NOT SHOWN, TO BE SHIPPED

ITEM NO.	QTY	UNIT	DESCRIPTION	NAME
1	1		CONT GP-MANUAL	
2	1		BOX-STORAGE	
3	1		ENGINE AIR	
4	1		RADIATOR GP-ATOR	
5	1		W/G GP-ENGINE	
6	1		COUPLING GP-FLY	
7	1		CRANK GP-TOIL	
8	1		CRANK GP-OIL	
9	1		GENERATOR AIR	
10	1		SENSOR GP-FRESS	
11	1		SENSOR GP-TEMP	
12	1		PANEL GP-COINT -A	
13	1		W/MS GP-ALT	
14	1		FLM GP	
15	1		FLM GP	
16	1		FLM GP	
17	1		BATTERIES	
18	1		W/MS GP	
19	1		W/MS GP	

367-9276